

Technical Specification  
**Pre-connectorized Fiber Optic Cable Distribution Box**  
**MCR ODB-8SX**



# MCR GROUP, INC.

## Contents

1. General .....	3
1.1 Description .....	3
1.2 Standards Comply .....	3
1.3 Applications Environment.....	3
2. Characteristics .....	4
3. Specifications.....	4
3.1 Mechanical specifications .....	4
4. Configuration.....	5
4.1 Main optical parameters .....	5
5. Product Picture .....	5
5.1 Product cable ways:.....	5
5.2 Fast Plug.....	6
5.3 Fiber optic cable bifurcation.....	7
5.4 Product cable ways:.....	7
5.5 Splicing tray .....	8
5.6 Accessories.....	9
6. Environmental characteristics.....	10
7. Installation: .....	10
7.1. Wall-mounted installation .....	10
7.2. Pole-mounted installation.....	10
7.3. The overhead structure .....	10
7.4. Wall-mounted installation (With drop cable storage tray) .....	11
7.5. Pole-mounted installation (With drop cable storage tray) .....	11
7.6. Aerial-mounted installation (With drop cable storage tray) .....	11
8. Connector operation .....	12
8.1 Pre-connected adapter - A ( E ) .....	12
8.2 Pre-connected adapter - B ( XL ) .....	12
8.3 Pre-connected adapter - C.....	12
8.4 Pre-connected adapter - D .....	13
8.5 Pre-connected adapter - E ( A ) .....	13
8.6 Pre-connected adapter - SC .....	14
8.7 Pre-connected adapter - G .....	14
9. Package.....	14

## 1. General

### 1.1 Description

Pre-connectorized optical distribution box as the most advanced FTTX network distribution node equipment, provide quick and reliable connection, good protection and management for the FTTX network.

Production type	Classification
MCR ODB-8SX	Pre-connectorized fiber optic cable distribution box



Appearance of MCR ODB-8SX

### 1.2 Standards Comply

The production offered by FTTXTECH are designed, manufactured and tested according to the standards as follows:

ITU-T G.652	Characteristics of a single-mode optical fibre
IEC 60794-1-1	Optical fibre cables-part 1-1: Generic specification-General
IEC 60794-1-2	Optical fibre cables-part 1-2: Generic specification-Basic optical cable test procedure

### 1.3 Applications Environment

Item	Value
Operation temperature	-40 °C~+65 °C
Installation temperature	-15 °C~+40 °C
Storage temperature	-45 °C~+75 °C
Atmospheric pressure	≤85% (+30°C)
Relative humidity	70KPa~106Kpa

## 2. Characteristics

- 2.1. Advanced structure design, easy operation and reasonable routing.
- 2.2. Material: PC+ABS.
- 2.3. Moisture proof, waterproof, dust-proof, anti-aging.
- 2.4. Protection level up to IP65.
- 2.5. 1 oval optical cable entry, 2 branch optical cable entries and 8 pre-connected adapters.
- 2.6. Various types of splice trays are available.
- 2.7. Installation method: pole-mounted, aerial-mounted, wall-mounted.
- 2.8. It can be equipped with drop cable storage tray to meet the storage of 50 meters 5mm round cable.

## 3. Specifications

### 3.1 Mechanical specifications

Item	Specifications	Remark
Material of housing	PC+ABS	
Material of internal components	PC+ABS/ABS	
Material of metal accessory	High-quality stainless steel	
External dimension(mm)	319.3*200*97.5 (A*B*C)	
Installation hole position(mm)	52*166*166 (DxExF)	
Color	PANTONE 428C	Customizable
Size and quantity of optical cable hole	1 oval optical cable entry, 2 branch optical cable entries and 8 pre-connected adapters	
Fusion capacity(Max)	48	Tray A ,12x4=48, 2 layers of heat-shrinkable splice protection sleeve.
	64	Tray B, 8x8=64, 1 layer of heat-shrinkable splice protection sleeve.
	96	Tray C, 8x12=96, 1 layer of heat-shrinkable splice protection sleeve.
	96	Tray D,Tray E, 24x4=96, 2 layers of heat-shrinkable splice protection sleeve.
	108	Max:1C+4D=108
Micro PLC Splitter	1x2	Splitter size : 60x7x4mm.
	1x4	Can be installed in type A and type E splicing tray, 1 PC per splicing tray.
	1x8	
	1*16	Splitter size : 60x12x4mm. Can be installed in type A-1, and type E-1 splicing tray, 1 PC per splicing tray.
Fiber cable diameter of the uncut pass through port(mm)	Φ8~Φ18	
Fiber cable dimension of branch cable port (mm)	Φ16	
IP protection level	IP65	
Flammability	HB	It can be customized according to needs.
Neutral salt spray test (NSS)	48 h	

# MCR GROUP, INC.

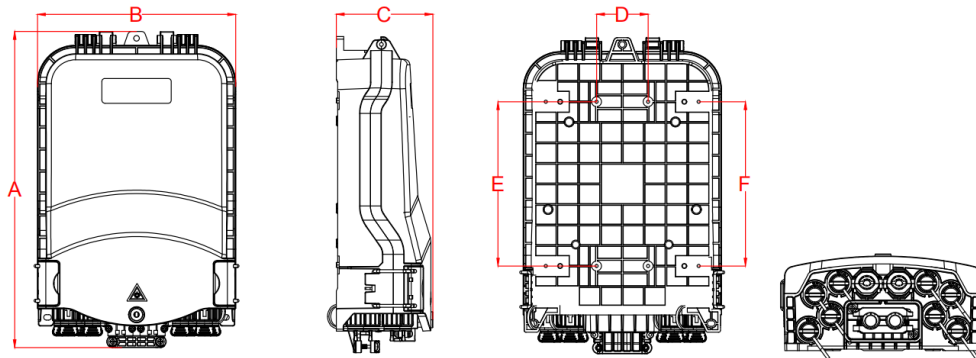

## 4. Configuration

### 4.1 Main optical parameters

Splitter or pigtail	IL(dB)	RL(dB)	IL(dB)	Test method
	Pigtail/Splitter		Distribution box	
Pigtail-SC/APC-00-SM-SX(1C1F)-OD0.9MM-PVC-G657A2-Cable Color(Default)-Indoor-RoHS-1.5m	≤0.3	≥55dB	≤0.5	IL: IEC61300-3-4 Method B RL: IEC61300-3-6 Method 1
1x2 PLC Splitter, with SCAPC connector	≤4.0	≥55dB	≤4.2	
1x4 PLC Splitter, with SCAPC connector	≤7.4	≥55dB	≤7.6	
1x 8 PLC Splitter, with SCAPC connector	≤10.5	≥55dB	≤10.7	
1x 16 PLC Splitter, with SCAPC connector	≤13.5	≥55dB	≤13.7	

The optical parameters shown in the table above are default values, and can be customized according to requirements.

## 5. Product Picture

### 5.1 Product cable ways:

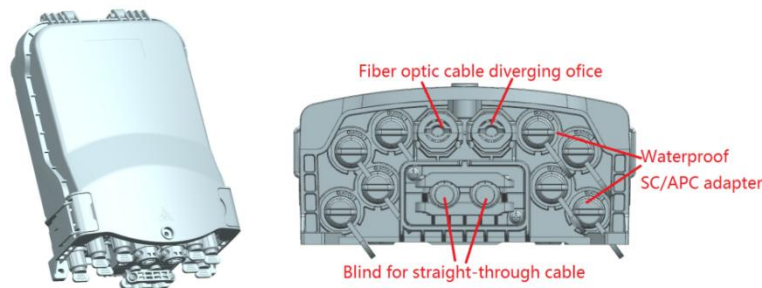

# MCR GROUP, INC.

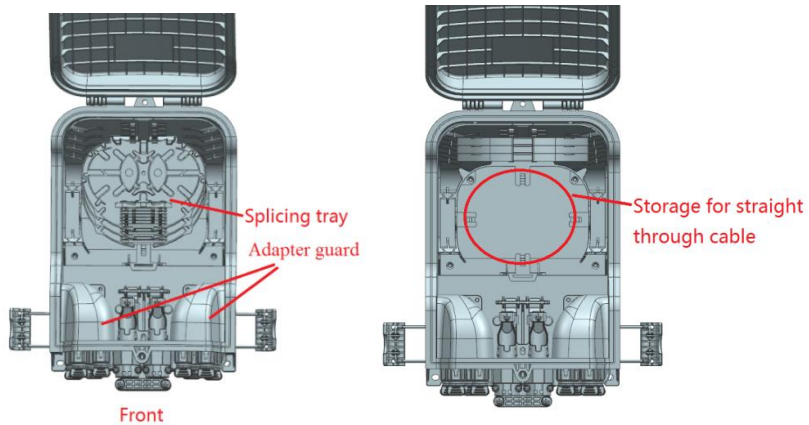

## 5.2 Fast Plug

Fast installation, fastening, and sealing of straight-through optical cable with the Fast Plug.

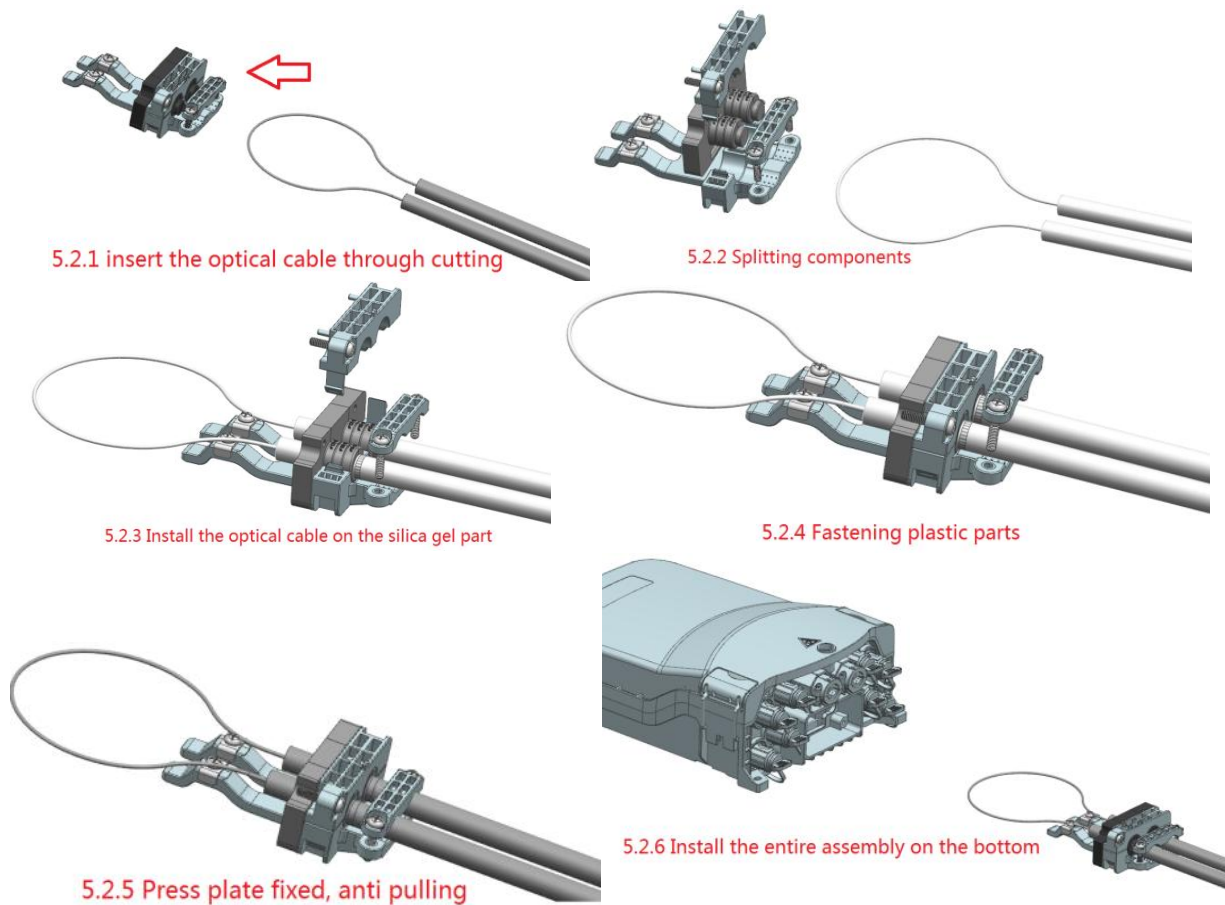

# MCR GROUP, INC.

## 5.3 Fiber optic cable bifurcation

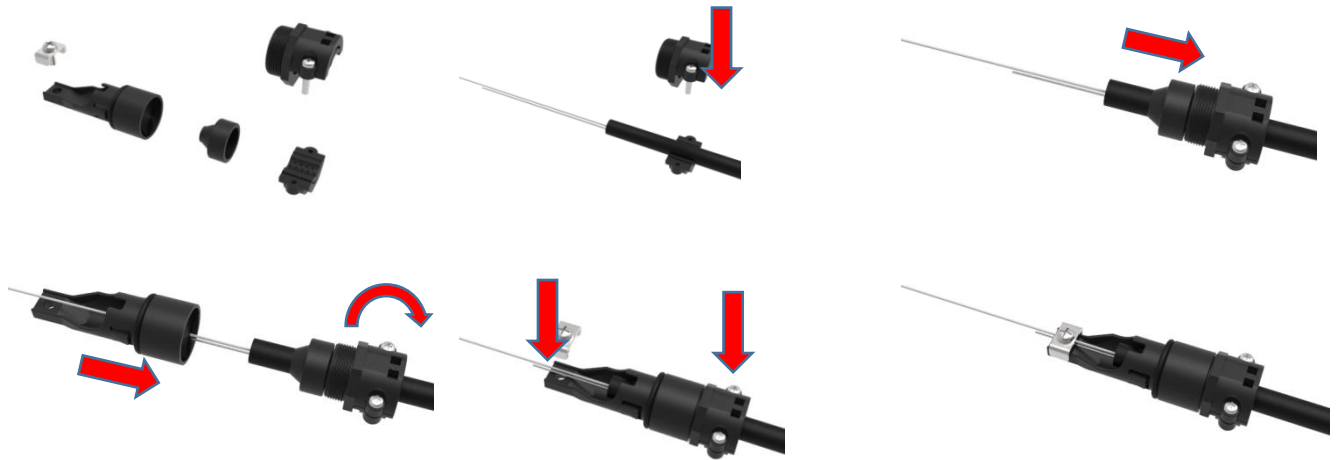

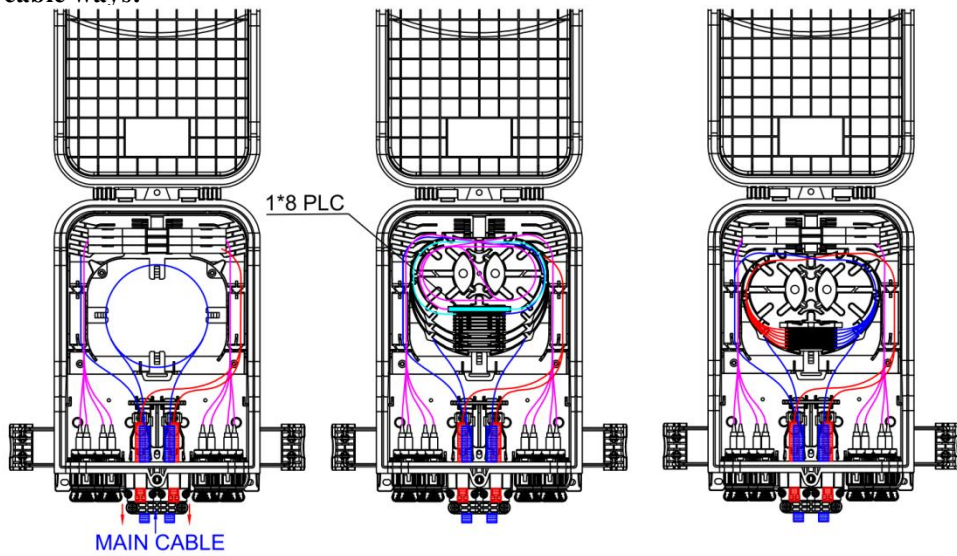

## 5.4 Product cable ways:







MCR ODB-8SX routing diagram

# MCR GROUP, INC.









## 5.5 Splicing tray

Item	Splicing tray A	Splicing tray B	Splitter tray A-1
Dimensions(H*W*D, mm)	134*104*8	134*104*4	134*104*8
Net weight (kg)	0.021	0.015	0.021
Picture			
Color	RAL7035	RAL7035	RAL7035
Material	PC+ABS	PC+ABS	PC+ABS
Splicing capacity of a tray(cores)	12 (2 layers of heat shrinkable protective sleeve)	8 (1 layer of heat shrinkable protective sleeve)	6 (2 layers of heat shrinkable protective sleeve)
Splitter capacity of a tray(PCS)	1 (PLC 1X2, 1X4, 1X8, 0.9mm fiber,60x7x4mm)	/	1 (PLC 1X16, 0.9mm fiber,60x12x4mm)
Maximum(PCS)	4	8	4
Default(PCS)	1	/	/
Note: 1. The above trays can be mixed according to requirements. 2. Configuration rules: 1A=2B=2C=1D=1E 3. The types of fiber discs are increasing continuously			

Item	Splicing tray C	Splicing tray D	Splicing tray E	Splicing tray E-1
Dimensions(H*W*D, mm)	136 * 104 * 4	136 * 104 * 8	135 * 125*8	135 * 125*8
Net weight (kg)	0.018	0.024	0.033	0.033
Picture				
Color	RAL7035	RAL7035	RAL7035	RAL7035
Material	PC+ABS	PC+ABS	PC+ABS	PC+ABS
Splicing capacity of a tray(cores)	12(1 layer of heat shrinkable protective sleeve)	24 (2 layers of heat shrinkable protection sleeve)	24 (2 layers of heat shrinkable protection sleeve)	18 (2 layers of heat shrinkable protection sleeve)
Splitter capacity of a tray(PCS)	/	/	1 (PLC 1X2, 1X4, 1X8, 0.9mm fiber,60x7x4mm)	1 (PLC 1X16, 0.9mm fiber,60x12x4mm)
Maximum(PCS)	8	4	4	4
Default(PCS)	2	/	/	/
Note: 1. The above trays can be mixed according to requirements. 3. Configuration rules: 1A=2B=2C=1D=1E 3. The types of fiber discs are increasing continuously				

# MCR GROUP, INC.

## 5.6 Accessories

No.	Part name	Reference picture	Unit	Quantity	Remark
1	Users' manual	/	pcs	1	EN
2	Splitter test report	/	pcs	1	EN
3	Key		pcs	1	"D" type
4	Heat-shrinkable protection sleeve		pcs	8	L=45mm
5	Nylon cable tie		pcs	10	3x100mm
6	Bare fiber protection tube		pcs	1	OD4mm x 50cm
7	Wall-mounted kit		set	1	Optional as customer's request. (Expanded plastic plug $\Phi 7.5 \times 40$ mm, Phillips self-tapping screws M5x40mm.)
8	Pole-mounted kit		set	1	Optional as customer's request
9	Aerial-mounted kit		set	1	Optional as customer's request
10	Drop cable storage tray		pcs	2	Optional as customer's request

## 6.Environmental characteristics

This product complies with the RoHS environmental protection directive, and the content of lead, cadmium, mercury, hexavalent chromium, polybrominated biphenyl (PBB) and polybrominated diphenyl ether (PBDE) does not exceed the limit.

## 7. Installation:

### 7.1. Wall-mounted installation

Drill 3 holes in the wall according to the dimension in table 2, place the expansion plug  $\Phi 7.5 \times 40$ , place the box to match up the holes and use screws to fasten.



Wall mounted installation

### 7.2. Pole-mounted installation

Pass the hoop ring through the slot of the back plate and fix it on the telecommunication pole

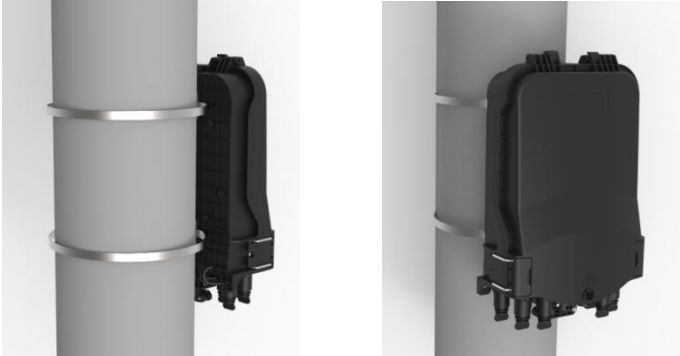

Pole mounted installation

### 7.3. The overhead structure

Tie the two installed on the chassis of the overhead hung on the wire, and then bolted, prevent the case fall off.(Pic 6)

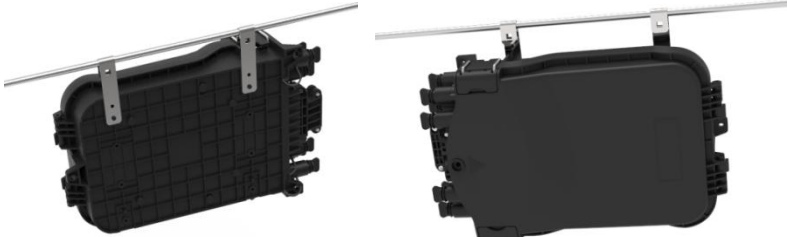

The overhead structure

## 7.4. Wall-mounted installation (With drop cable storage tray)

Drill 4 holes in the wall according to the dimension of the drop cable storage tray mounting hole, place the expansion plug  $\Phi 7.5 * 40$ , place the box to match up the holes, and fasten with the screws.



Wall-mounted installation (With drop cable storage tray)

## 7.5. Pole-mounted installation (With drop cable storage tray)

Pass the stainless steel belt through the slot of the drop cable storage tray and fix it on the pole with buckle.

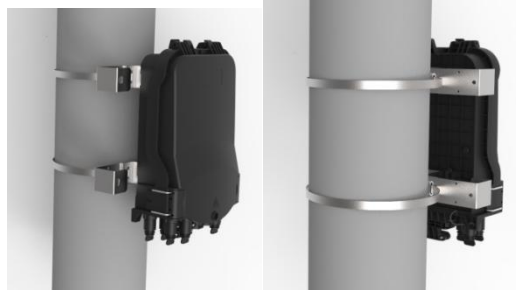

Pole-mounted installation (With drop cable storage tray)

## 7.6. Aerial-mounted installation (With drop cable storage tray)

Use the small metal plate to fix the distribution box to the messenger.

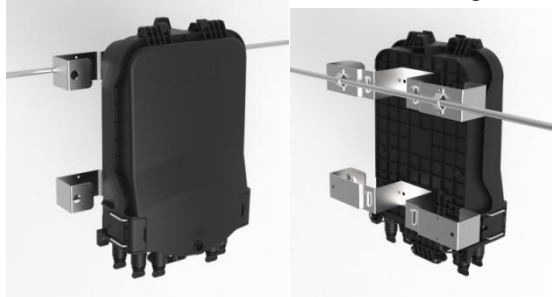

Aerial-mounted installation (With drop cable storage tray)

## 8. Connector operation

### 8.1 Pre-connected adapter - A ( E )

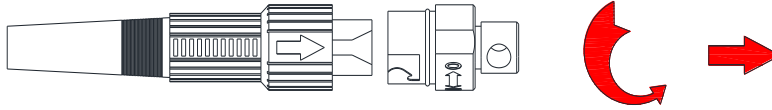

Rotate the arrow part of fiber connector counterclockwise and take out the dust cap.

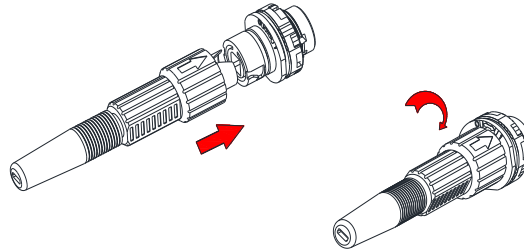

The arrow part of fiber connector is above, insert fiber connector into the socket and then rotate the arrow part clockwise.

### 8.2 Pre-connected adapter - B ( XL )

- Insert the SC optical fiber connector plug through the loose parts in turn, and then plug it into the adapter;
- Install XL pre connected adapter sheath on adapter with plastic key;
- Insert the plug of the snap spring into the sheath;
- The cable clamp shall be installed and the line shall be close to the plug;
- Screw the leather cable clamp seat cap on the sheath clockwise

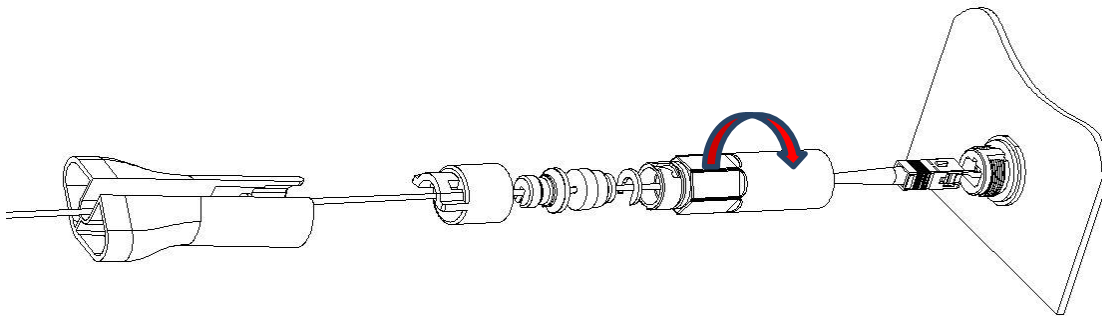

### 8.3 Pre-connected adapter - C

- Push the sliding ring on the optical fiber preformed plug in the direction of the arrow to remove the dust cap; press the button to take out the dust cap on the adapter in the direction of the arrow



# MCR GROUP, INC.

- Align the body of the preformed plug with the adapter buckle until it is fastened. Connect the two dust covers in the same way.



- The installed prefabricated plug pushes the sliding ring to release the buckle, and then pull the main body backward to separate it.



## 8.4 Pre-connected adapter - D

- Turn the pre connected plug anti clockwise and open the pre connected plug and dust cover in the direction of the arrow

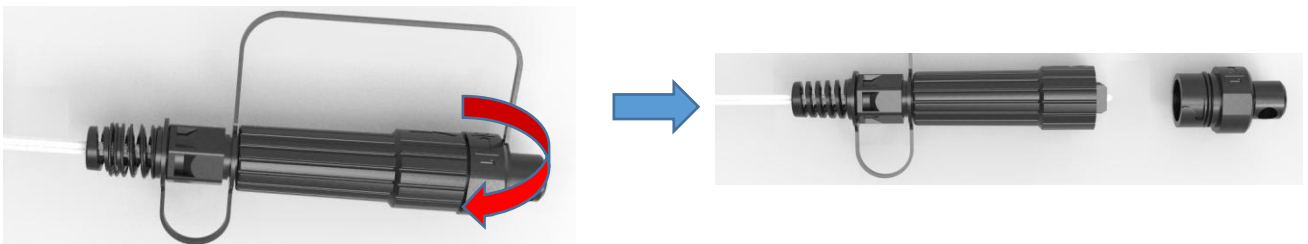

- Connect the pre connected plug D and the pre connected adapter D in the direction of the arrow, and rotate the plug clockwise to fix it

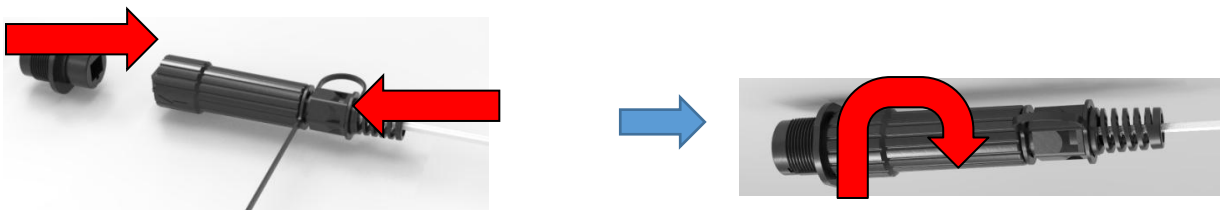

## 8.5 Pre-connected adapter - E ( A )

- Turn the pre connected plug anti clockwise and open the pre connected plug and dust cover in the direction of the arrow

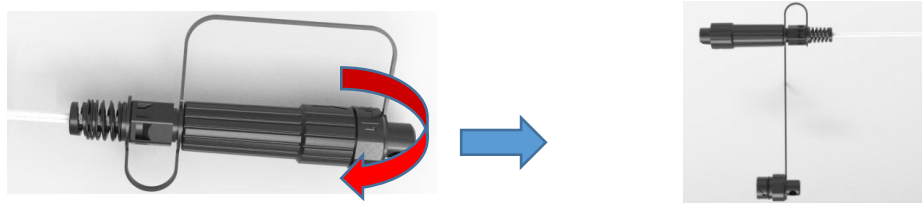

# MCR GROUP, INC.

- Connect the pre connected plug E and the pre connected adapter E in the direction of the arrow, and rotate the plug clockwise to fix it

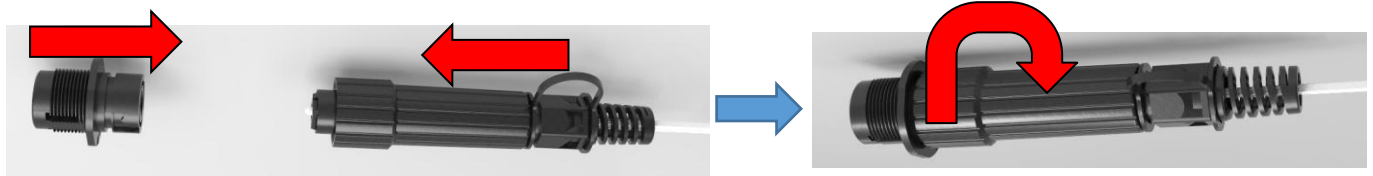

## 8.6 Pre-connected adapter - SC

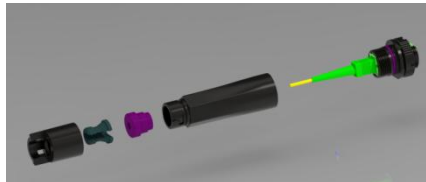

- Insert the SC optical fiber connector plug through the loose parts in turn, and then plug it into the adapter;
- Install XL pre connected adapter sheath on adapter with plastic key;
- Insert the plug of the snap spring into the sheath;
- The cable clamp shall be installed and the line shall be close to the plug;
- Screw the leather cable clamp seat cap on the sheath clockwise

## 8.7 Pre-connected adapter - G

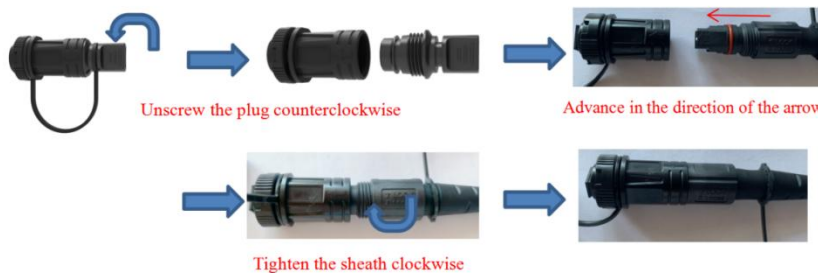

## 9.Package

Item	Material	Size(mm)	Quantity	Gross weight(kg)
Independent product packaging	Carton	340*215*120	1	1.3
Outer packaging carton	Carton	450*360*630	10	14
Note: Without drop cable storage tray				